

Micro-Fog® and Oil-Fog Tool Lubricators L73★ - ★★ - ★★★

Type	Port	Thread Form	Air Flow Direction	Drain	Bowl	Options
C....Oil-Fog	2....1/4"	A....PTF	P....Uni-directional	E....Closed bottom	D....Metal with plastic liquid level indicator	N....None
M....Micro-Fog	3....3/8"	B....ISO Rc taper		Q....Manual, 1/4 turn	P....Transparent with guard	P....Pyrex sight-feed dome
	4....1/2"	G....ISO G parallel			R....Metal with Pyrex liquid level indicator	Q....Quick fill nipple
					T....Transparent	

TECHNICAL DATA

Fluid: Compressed air
 Maximum pressure:
 Transparent bowl: 10 bar (150 psig)
 Metal bowl: 17 bar (250 psig)
 Operating temperature*:
 Transparent bowl: -20° to +50°C (0° to +125°F)
 Metal bowl: -20° to +80°C (0° to +175°F)
 * Air supply must be dry enough to avoid ice formation at temperatures below +2°C (+35°F).
 Start point (minimum flow required for lubricator operation) at 6,3 bar (90 psig) inlet pressure:
 0,71 dm³/s (1.5 scfm)
 Maximum recommended flow: 28 dm³/s (60 scfm). Air flows above 28 dm³/s (60 scfm) create excessive air velocity, turbulence, and pressure losses. In addition, the fog produced by the lubricator will wet out on the pipe walls and will not be carried by the compressed air to the point of application.
 Typical flow with 6,3 bar (90 psig) inlet pressure and 0,5 bar (7 psig) pressure drop:
 Oil-Fog models: 75 dm³/s (158 scfm)
 Micro-Fog models: 65 dm³/s (138 scfm)
 Nominal bowl size: 0,1 litre (3.5 fluid ounce)
 Manual drain connection: 1/8"

Materials:

Body: Aluminum
 Bowl:
 Transparent: Polycarbonate
 Transparent with guard: Polycarbonate, steel guard
 Metal: Aluminum
 Metal bowl liquid level indicator lens: Transparent nylon
 Sight-Feed dome: Transparent nylon
 Elastomers: Neoprene and nitrile

REPLACEMENT ITEMS

Service kit (includes items circled on exploded view)4382-600
 Liquid level lens kit (43, 45, 46, 47)4380-020
 Manual drain (18, 19, 20)619-50

INSTALLATION

- Shut-off air pressure. Install lubricator in air line -
 - vertically (reservoir down),
 - with air flow in direction of arrow on body,
 - downstream of filters and regulators
 - upstream of cycling valves,
 - as close as possible to the device being lubricated,
 - Oil-Fog Models - Not more than 5,2m (15 feet) from the device being lubricated, and at the same height or higher than the device.
- Connect piping to proper ports using pipe thread sealant on male threads only. Do not allow sealant to enter interior of unit.
- Push reservoir, or reservoir with guard, into body and turn fully clockwise before pressurizing.

RECOMMENDED LUBRICANTS

Use a good quality, light, misting type oil for compressed air tools. See Norgren publication N/AL.8.900.935.

FILL RESERVOIR (OIL-FOG LUBRICATORS)

Remove fill plug (2), add oil, and reinstall fill plug. Fill plug can be removed and oil added without shutting off air pressure to the lubricator. Fill to maximum fill line on transparent reservoirs. Oil level must always be visible in lens on metal reservoirs. **DO NOT OVERFILL.**

NOTE: Oil fill plug (2) seals easily. Tighten finger-tight only.

FILL RESERVOIR (MICRO-FOG LUBRICATORS)

Shut off inlet air pressure and reduce pressure in reservoir to zero. Remove fill plug (2), add oil, and reinstall fill plug. **Do not remove the fill plug when the reservoir is pressurized, as oil will blow out the fill plug hole.** Micro-fog lubricators can be filled under pressure only if equipped with the optional quick fill cap (4), which requires a quick fill connector and oil pump. Fill to maximum fill line on transparent reservoirs. Oil level must always be visible in lens on metal reservoirs. **DO NOT OVERFILL.**

ADJUSTMENT

- Turn on system pressure.
- Adjust lubricator drip rate only when there is a constant rate of air flow thru the lubricator. Monitor drip rate thru sight feed dome (6).
- Oil-Fog Lubricators** - Determine the average rate of flow thru the lubricator. Turn green rotator in sight feed dome (6) to obtain one drop per minute for each 5 dm³/s (10 scfm). For example, if the average flow is 19 dm³/s (40 scfm), set the drip rate at 4 drops per minute. Turn rotator counterclockwise to increase and clockwise to decrease the drip rate. Total travel of rotator is 320°.
- Micro-Fog Lubricators** - Determine the average rate of flow thru the lubricator. Turn red rotator in sight feed dome (6) to obtain the recommended drops per minute. **See Drip Rate Chart.** Turn rotator counterclockwise to increase and clockwise to decrease the drip rate. Total travel of rotator is 320°.

Drip Rate Chart for Micro-Fog Lubricators

Flow - dm ³ /s (scfm)	Drops per Minute
2 (5)	3
5 (10)	4
10 (20)	7
15 (30)	9
20 (40)	12
25 (50)	15

- Monitor the device being lubricated for a few days following initial adjustment. Adjust the drip rate if the oil delivery at the device appears either excessive or low.

DISASSEMBLY

- Shut off inlet pressure. Reduce pressure in inlet and outlet lines to zero. Loosen fill plug (2).
- Remove reservoir - push into body and turn counterclockwise.
- Disassemble in general accordance with the item numbers on exploded view. Do not remove the manual drain unless replacement is necessary. Remove and replace drain assembly only if drain malfunctions. Do not remove siphon tube (49). Remove and replace items 50 thru 55 only if lubricator malfunctions. O-ring (55) is only used on Micro-Fog lubricators.

CLEANING

- Clean plastic reservoir with warm water only. Clean other parts using warm water and soap.
- Dry parts. Blow out internal passages in body with clean, dry compressed air.
- Inspect parts. Replace parts found to be damaged. If plastic reservoir shows signs of cracking or cloudiness, replace with a metal reservoir.

ASSEMBLY

- Lubricate o-rings, the portion of the manual drain body (18, 28, 37) that contacts the bowl, and the hole in the manual drain body that accommodates the stem of drain valve (19, 29, 38) with o-ring grease.
- Assemble lubricator as shown on exploded view.
- Torque Table

	N-m (Inch-Pounds)
2 (Fill Plug), 4 (Quick-fill cap)	1,1 to 1,6 (10 to 14)
6, 8 (Dome)	2,3 to 2,8 (20 to 25)
43 (Screw)	1,3 to 2,0 (12 to 18)
50 (Screw)	2,0 to 2,5 (18 to 22)
- Push reservoir, or reservoir with guard, into body and turn fully clockwise.

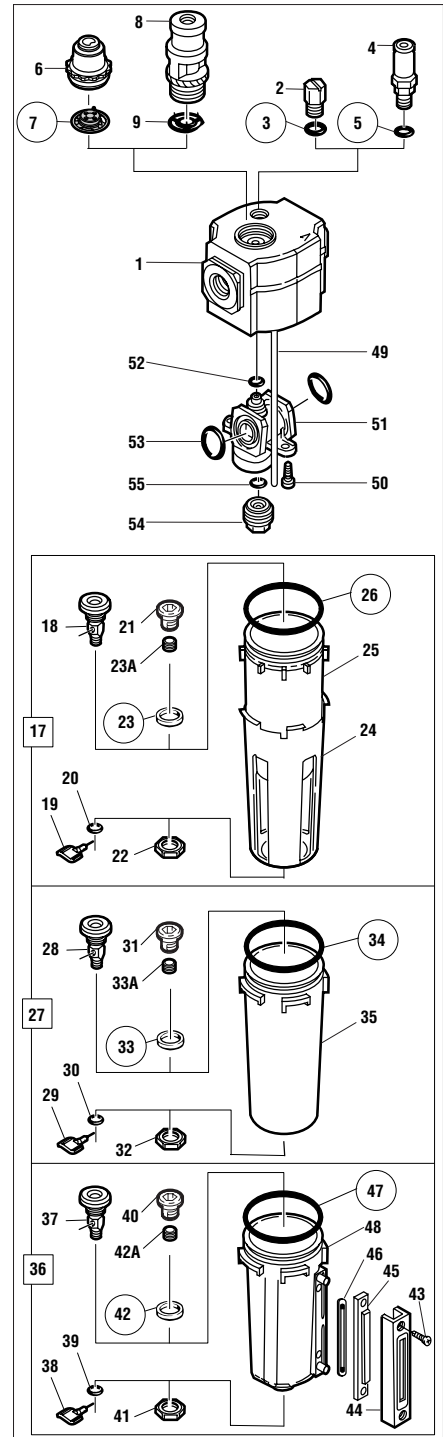

WARNING

These products are intended for use in industrial compressed air systems only. Do not use these products where pressures and temperatures can exceed those listed under **Technical Data**.

Polycarbonate plastic reservoirs can be damaged and possibly burst if exposed to such substances as certain solvents, strong alkalies, compressor oils containing ester-based additives or synthetic oils. Fumes of these substances in contact with the polycarbonate reservoir, externally or internally, can also result in damage. Clean with warm water only.

Use metal reservoir in applications where a plastic reservoir might be exposed to substances that are incompatible with polycarbonate.

In lubrication applications some oil mist may escape from the point of use to the surrounding atmosphere. Users are referred to safety and health standards for limiting oil mist contamination and utilization of protecting equipment.

Before using these products with fluids other than air, for nonindustrial applications, or for life-support systems consult Norgren.